

FilterTable

EN – Operating Manual

Typenschild einkleben

1	General	- 6 -
1.1	Introduction	- 6 -
1.2	References to copyright and industrial property rights	- 6 -
1.3	Notes for the operating company	- 6 -
2	Safety	- 8 -
2.1	General information	- 8 -
2.2	Information on signs and symbols	- 8 -
2.3	Markings/signs to be affixed by the operating company	- 9 -
2.4	Safety instructions for operating staff	- 9 -
2.5	Safety instructions for maintenance/troubleshooting	- 10 -
2.6	Notes regarding special types of hazard	- 10 -
3	Product information	- 13 -
3.1	Functional description	- 13 -
3.2	Intended use	- 14 -
3.3	Reasonably foreseeable misuse	- 15 -
3.4	Markings and signs on the product	- 16 -
3.5	Residual Risk	- 16 -
4	Transport and Storage	- 18 -
4.1	Transport	- 18 -
4.2	Storage	- 18 -
5	Assembly	- 19 -
6	Use	- 27 -
6.1	Qualification of the operating personnel	- 27 -
6.2	Operating elements	- 27 -
6.3	Commissioning	- 28 -
7	Maintenance	- 29 -
7.1	Care	- 29 -
7.2	Maintenance	- 30 -
7.2.1	Changing the filter – Safety instructions	- 30 -
7.2.2	Changing filters	- 32 -
7.3	Maintenance - Cleaning the perforated plate support	- 34 -
7.4	Troubleshooting	- 36 -
7.5	Emergency measures	- 36 -

8 Disposal	- 38 -
8.1 Plastics	- 38 -
8.2 Metals	- 38 -
8.3 Filter elements	- 38 -
9 Annex	- 39 -
9.1 EC compliance statement	- 39 -
9.2 UKCA Declaration of Conformity	- 40 -
9.3 Technical data	- 41 -
9.4 Dimensions sheet	- 42 -
9.5 Spare parts and accessories	- 43 -
9.6 Table accessory GWT	- 44 -

1 General

1.1 Introduction

This manual is an essential aid for the proper and safe operation of the product.

These operating instructions contain important information to ensure safe, proper and efficient operation of the product. Observing these instructions helps avoiding danger, reducing repair costs and downtimes and increasing the reliability and service life of the product. The operating instructions must be kept available at all times and have to be read and applied by every person who is assigned to work on or with the product.

These include amongst others:

- the operation and troubleshooting during operation
- the maintenance (care, maintenance, repair)
- the transport
- the assembly
- the disposal

Technical modifications and errors expected.

1.2 References to copyright and industrial property rights

These Operating Instructions should be kept confidential. They should be made accessible only to authorised persons. They may be passed on to third parties only with the written consent from KEMPER GmbH, referred to as manufacturer in the following.

All documents are protected under the Copyright Act. The reproduction and distribution of documents, including excerpts, as well as re-use and passing on of their contents is not permitted. Unless this is expressly permitted in writing.

Violations are liable to prosecution and liable for damages. The manufacturer reserves the right to exercise all intellectual property rights.

1.3 Notes for the operating company

The operating instructions are an essential part of the product.

The operating company must ensure that the operating personnel is aware of the contents of this manual.

Based on national regulations for accident prevention and environmental protection, the operating instructions are to be supplemented by the operating company's own operating instructions, including information on regulatory and reporting requirements to meet specific operating requirements, such as work organisation, work flow and staff employed. In addition to the operating instructions and the relevant obligatory

regulations for accident prevention applicable in the country of use, it is also imperative to comply with the recognised technical rules for safe and professional handling.

Without prior consent from the manufacturer, the operating company may not carry out any changes, conversions or additions to the product which may impair safety. Spare parts used must comply with the manufacturer's specified technical requirements. This is always the case with original replacement parts.

Only use trained and instructed staff for the operation, maintenance, repair and transport of the product. Clearly define for staff who is responsible for operation, maintenance and transport.

2 Safety

2.1 General information

The product is designed and built according to state-of-the-art technology and the recognised safety rules and regulations. When operating the product, technical hazards for the operator or impairment of the product as well as other property may occur, if:

- it is not operated by trained or instructed personnel
- it is not used for the purpose intended and/or
- it is improperly maintained

2.2 Information on signs and symbols

▲ DANGER

This symbol in conjunction with the signal word "Danger" indicates imminent danger. Non-adherence of the safety note leads to death or serious injuries.

▲ WARNING

The symbol in conjunction with the signal word "Warning" indicates a potentially dangerous situation. Non-adherence to the safety notice may lead to death or serious injuries.

▲ CAUTION

The symbol in conjunction with the signal word "Caution" indicates a potentially dangerous situation. Non-adherence of the safety note may lead to slight or negligible injuries.

May also be used for warnings against property damage.

NOTE

The general information is simple additional information which does not warn about personal injury or property damage.

1. Enumerations of action steps are marked as numbers with a dot, where the order is important.
- Bullet points indicate lists of parts in a legend or instructions for which the sequence is unimportant

2.3 Markings/signs to be affixed by the operating company

The operating company is obliged to post further markings and signs on the product and the surrounding area if necessary.

Such markings and signs might be related, for example, to the requirement for wearing personal protective equipment.

2.4 Safety instructions for operating staff

Before use, the operator of the product must be instructed through information, instructions and training on the handling of the product and the materials and aids to be used.

The product system may only be used in technically perfect condition, for its intended purpose, in full awareness of the safety aspects and potential dangers and in accordance with these instructions. All errors, especially those that may affect safety, must be removed immediately.

Every person who is charged with commissioning, operation or maintenance must have fully read and understood these operating instructions. This specifically applies to staff who only operate the product occasionally.

The operating instructions must always be within reach of the product.

We accept no liability for any damages or injuries caused by failure to observe these operating instructions.

The relevant accident prevention regulations and other generally recognised safety and occupational health regulations must be observed.

The responsibilities for the various activities included in maintenance and repair must be clearly defined and adhered to. Only then will human error - especially in dangerous situations - be avoided.

The operating company is to enforce wearing of personal protective equipment by operating and maintenance staff. These include in particular safety shoes, safety glasses and gloves.

Do not wear loose, long hair, loose clothing or jewellery. In theory, there is a risk of getting caught on something, or being pulled in or dragged along by moving parts.

If there are any safety-related changes to the product, immediately halt the process, secure it and report the occurrence to the relevant authority/person!

Work on the product may only be carried out by reliable, trained staff. Observe the minimum legal age.

Staff who require training, teaching or instructing or staff who undergo a general apprenticeship may only operate the product under the supervision of an experienced member of staff.

2.5 Safety instructions for maintenance/troubleshooting

Service and maintenance doors must be freely accessible at all times.

Setting up, maintenance and repair work and troubleshooting must only be performed when the product is switched off.

Always tighten bolt connections that have been loosened during repair work. If specified, tighten the relevant bolts with a torque wrench.

In particular, protect connections and screw connections from dirt or care products at the beginning of maintenance/repair/care

The time frames for periodic testing/inspections stipulated or specified in the operating instructions must be observed.

Before disassembling, mark the parts that belong together.

2.6 Notes regarding special types of hazard

⚠ DANGER

Danger of electric shock!

Any work on the electrical equipment of the product must only be performed by a qualified electrician or by operating personnel under the direction and supervision of a qualified electrician in accordance with electronic regulations.

Before opening the product, pull the plug, if available, and secure it against accidental switch-on.

For faults with the product's electrical energy supply, immediately switch the product off at the on/off switch and if available, also pull the plug.

Use only original fuses with the prescribed amperage.

Electrical components, on which inspection, maintenance and repair work must be carried out, must be disconnected from the power supply. Secure equipment that has been used for disconnection against unintentional or automatic reconnection. Firstly check that no voltage is present in activated, electrical components, then isolate adjacent components under voltage. When making repairs, ensure that constructive characteristics are not altered in a way that reduces safety.

Check cables regularly for damage and replace if necessary.



CAUTION: Automatically Operated Device – To Reduce The Risk Of Injury Disconnect From Power Supply Before Servicing.

WARNING: To Reduce The Risk Of Electric Shock, Do Not Expose to Water or Rain.

ATTENTION: Appareil fonctionnant automatiquement – afin de réduire les risques de blessure, débrancher l'alimentation électrique de procéder à l'entretien.

AVERTISSEMENT: Pour réduire le risque de choc électrique, ne pas exposer à l'eau ou à la pluie.

⚠ WARNING**Electric shock if earthing is missing!**

If the protective earth connection of devices is missing or incorrectly executed, high voltages may be present on exposed parts or housing parts which, if touched, can lead to serious injury or death.

⚠ WARNING**Electric shock if an unsuitable power supply is connected!**

The connection of an unsuitable power supply can cause parts that can be touched to be under dangerous voltage. Contact with dangerous voltage can lead to serious or fatal injury.

For electrical connection data, see the name plate of the product

Power supply

The product is designed for the mains voltage indicated on the name plate. If mains cables or mains plugs are not fitted to the product, they must be fitted in accordance with national standards.

⚠ CAUTION**Insufficiently dimensioned electrical installation can lead to serious damage to property.**

The mains supply line and its fuse protection must be designed in accordance with the existing power supply. Observe the technical data on the name plate.

The mains fuse should be equipped with at least a **category C** circuit breaker.

⚠ WARNING**Danger due to the product falling over!**

Serious injuries due to the product tilting/falling over.

- Before moving, release the brakes on the castors (if available).
- Move and set down the product only on flat, smooth floor coverings.
- Only move or transport the product using the transport lugs/handles provided.
- Observe the total weight, attachment points and centre of gravity of the load.
- Do not sit on or climb onto the product.
- Only transport the product without load/workpieces.

⚠ WARNING**Health hazards caused by welding fume particles**

Do not inhale welding dust / smoke! Serious injury to the lungs and respiratory tract is possible!

Sweat smoke contains substances that can cause cancer!

Skin contact with cutting and welding fumes etc. can cause skin irritation in sensitive persons!

Repair and maintenance work on the product may only be carried out by trained and authorised personnel while complying with the safety rules and the applicable accident prevention regulations.

To avoid contact with and inhalation of the dust particles, wear disposable overalls, protective goggles, gloves and a suitable Class FFP2 respiratory protection filter mask in accordance with EN 149.

The release of hazardous dust particles during repair and maintenance is to be avoided to ensure that persons not charged with the task are not affected.

⚠ CAUTION**Health hazard due to noise!**

The product can produce noise, please refer to information in the technical data. In connection with other machines and/or local conditions, a higher noise level can occur at the operation site of the product. In this case, the operating company is obliged to provide the operating personnel with the appropriate protective equipment.

3 Product information

3.1 Functional description

The product is a welding table with an integrated welding fumes filter device that extracts welding fumes at the point where they are produced and extracts them with a filter efficiency of more than 99%.

The extracted contaminated air is cleaned using a 2-stage filter method and then fed back into the workspace.

The dust particles released during the work process are collected via the extraction table. Coarse dust particles are pre-filtered in the aluminium mesh. The fine dust particles are then separated in the main filter.

The welding table can be equipped with modular clamping tools. System 16 - 6 mm www.german-weldingtools.com

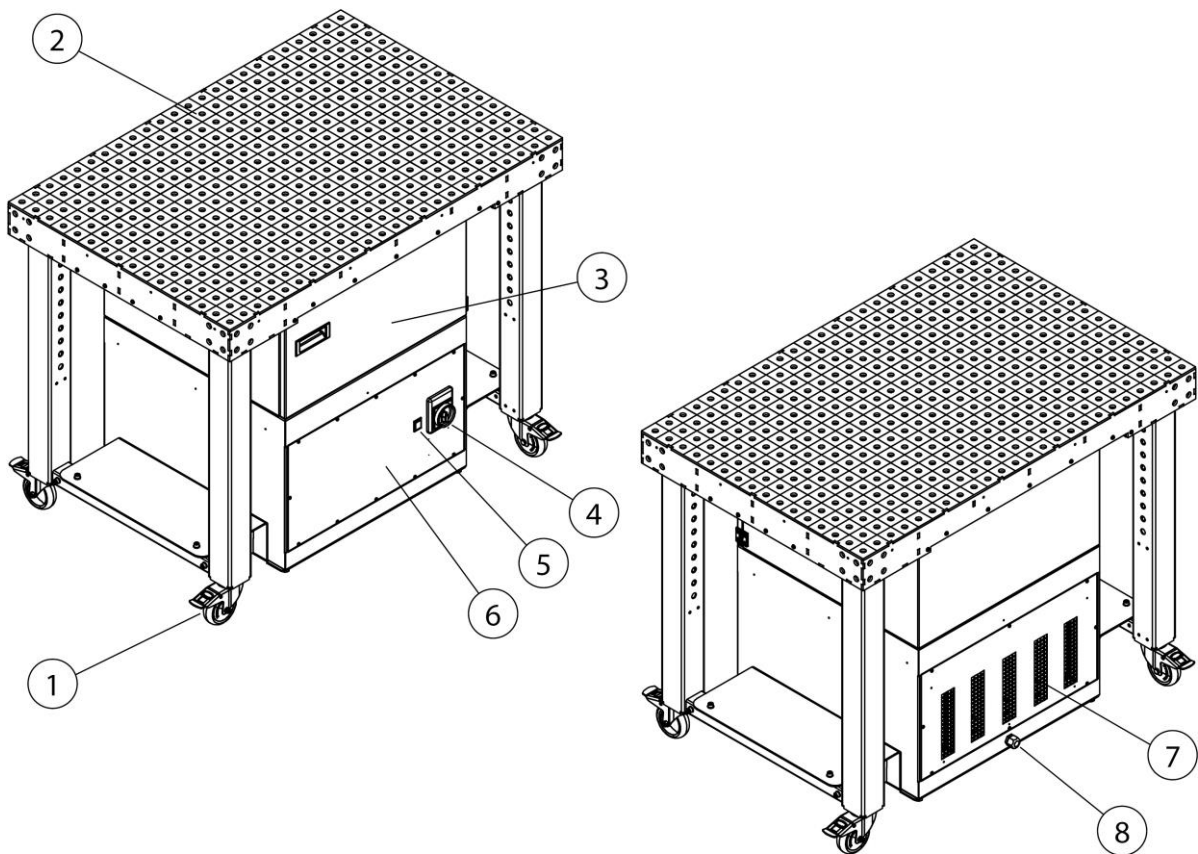

Fig. 1: Positions on the product

Item	Description	Item	Description
1	Swivel castor with brake	5	Signal light, filter change note
2	Perforated sheet support	6	Fan component
3	Filter component	7	Clean air outlet
4	Main switch on/off	8	Mains supply connection

Tab. 1: Positions on the product

3.2 Intended use

The product is designed to extract and filter out the welding fumes produced when welding metallic materials at the point of origin. In general, the product can be used for all work processes in which welding fumes are released. However, care must be taken that no glowing sparks are drawn into the product.

Dimensions and further product details that must be observed can be found in the technical data.

NOTE



Only products labelled with the W3 sticker have been tested and certified accordingly. See also chapter Technical data: Welding fume class and test standard.

NOTE

When welding alloyed or high-alloy steels with filler metals above 5% chromium/nickel, carcinogenic CMR substances (carcinogenic, mutagenic, reprotoxic) are released. In accordance with official regulations, only tested and approved products may be operated in Germany to extract these harmful smoke particles using the so-called recirculation method.

Only products that meet the requirements of welding fume separation class W3/IFA certified may be operated for the aforementioned welding processes using the recirculation method.

When extracting welding fumes with carcinogenic components (e.g. chromates, nickel oxides, etc.), the requirements of TRGS 560 (technical rules for HAZMAT) and TRGS 528 (welding work) must be obeyed.

NOTE

The information in the "Technical data" chapter must be observed and strictly adhered to.

Intended use also includes observation of the instructions and information on

- safety
- operation and control
- maintenance and servicing

contained in this manual.

Any other use or use going beyond this is considered improper use. The company operating the product is solely responsible for any damage resulting from it. This also applies to unauthorised modifications to the product.

3.3 Reasonably foreseeable misuse

No reasonable, foreseeable misuse is possible that could lead to dangerous situations with personal injury when working with the product whilst adhering to its intended use.

The operation of the product in industrial areas that do not comply with the requirements for explosion protection is not permissible.

Furthermore, the operation is prohibited for:

1. Processes that are not in the intended use list and in which the extracted air is:
 - is mixed with sparks, e.g. from grinding processes, which due to their size and quantity might lead to damage to the filter media or even to a fire;
 - mixed with liquids and the resulting contamination of the air flow with vapours containing aerosols and oils;
 - mixed with highly flammable, combustible dust and/or with substances that can form explosive mixtures or atmospheres;
 - is mixed with other aggressive or abrasive dust that could damage the product and the filter elements employed;
 - is mixed with organic, toxic substances or a proportion of substances that are released when cutting the material.

2. Outdoor locations where the product is exposed to weather conditions because the product must only be installed in closed buildings.
If there is an outdoor variant of the product available, this may be installed outside. Please note that additional accessories may be required for the outdoor installation.

3.4 Markings and signs on the product

Various markings and signs are affixed to the product. If these are damaged or removed, please replace them immediately with new ones in the same location.

The operating company is obliged to post further markings and signs on the product and the surrounding area if necessary.

Such notes and signs might be related, for example, to the requirement for wearing personal protective equipment.

In the country of use, additional required safety instructions and pictograms can be provided by the manufacturer in accordance with applicable law.

3.5 Residual Risk

Even when all safety rules are observed, when operating the product a residual risk remains, as described below.

All persons working on and with the product must be aware of these residual risks and follow the instructions that prevent these residual risks from causing accidents or damages.

⚠ WARNING

Danger of serious injury to the lungs and respiratory tract – always wear respiratory protection, Class FFP2 or higher.

Skin contact with welding fume particles may cause skin irritation in sensitive persons – wear protective clothing.

Before starting the welding process, ensure that the product is properly adjusted and in operation. The filter elements must be complete and in undamaged condition.

The connected detection element must reliably detect the welding fumes. For the correct positioning, refer to the documentation of the detection element.

When changing the filter inserts, skin contact with the separated dust particles may occur and parts of the dust particles may also be stirred up by the work. Respiratory protection and protective clothing must be worn.

Embers in the filter elements may cause smouldering fires – switch off the product, close the damper flap in the collection element if fitted and let the device cool down in a controlled manner.

4 Transport and Storage

4.1 Transport

⚠ DANGER

Life-threatening crushing possible when loading and transporting the product!

Improper lifting and transporting may cause the pallet (if present) to tilt and fall!

- Never stand under suspended loads.
- Observe the permissible loads of the transport and lifting aids.
- Observe the applicable accident prevention and occupational safety regulations.

For transporting products with a pallet, use a suitable pallet truck or forklift. The weight of the product can be found on the name plate.

4.2 Storage

The product must be stored in its original packaging at an ambient temperature of 20 °C to +50 °C in a dry and clean place. The packaging must not be loaded by other objects.

The storage duration is not critical for all products.

5 Assembly

Instructions for safe installation of the product

NOTE

The operating company of the product may only assign specialists to carry out independent assembly.

- At least two people are needed to assemble the product.
 - It must be ensured that the installation location and point of use of the product provides sufficient load-bearing capacity and good stability.
-

⚠ DANGER

Falling or tipping parts may cause life-threatening injuries!

Tipping or falling loads lead to severe to fatal injuries.

- Observe the total weight, attachment points and centre of gravity of the load.
 - Observe the transport instructions and symbols on the transported goods.
-

⚠ WARNING

Incorrect connections may cause serious injuries!

Please note the necessary safeguards and only have the product connected by trained specialists.

NOTE

Ensure that the welding current return line between the workpiece and the welding machine has a low resistance and that connections between the workpiece and the product are avoided so that the welding current cannot flow back to the welding machine via the product's protective conductor.

NOTE

If add-on products are also present, follow the appropriate manuals when assembling them.

Proceed to mount the product as follows:

1. Remove the packaging material and the tensioning straps.
2. Lift the filter unit and individual parts off the pallet.

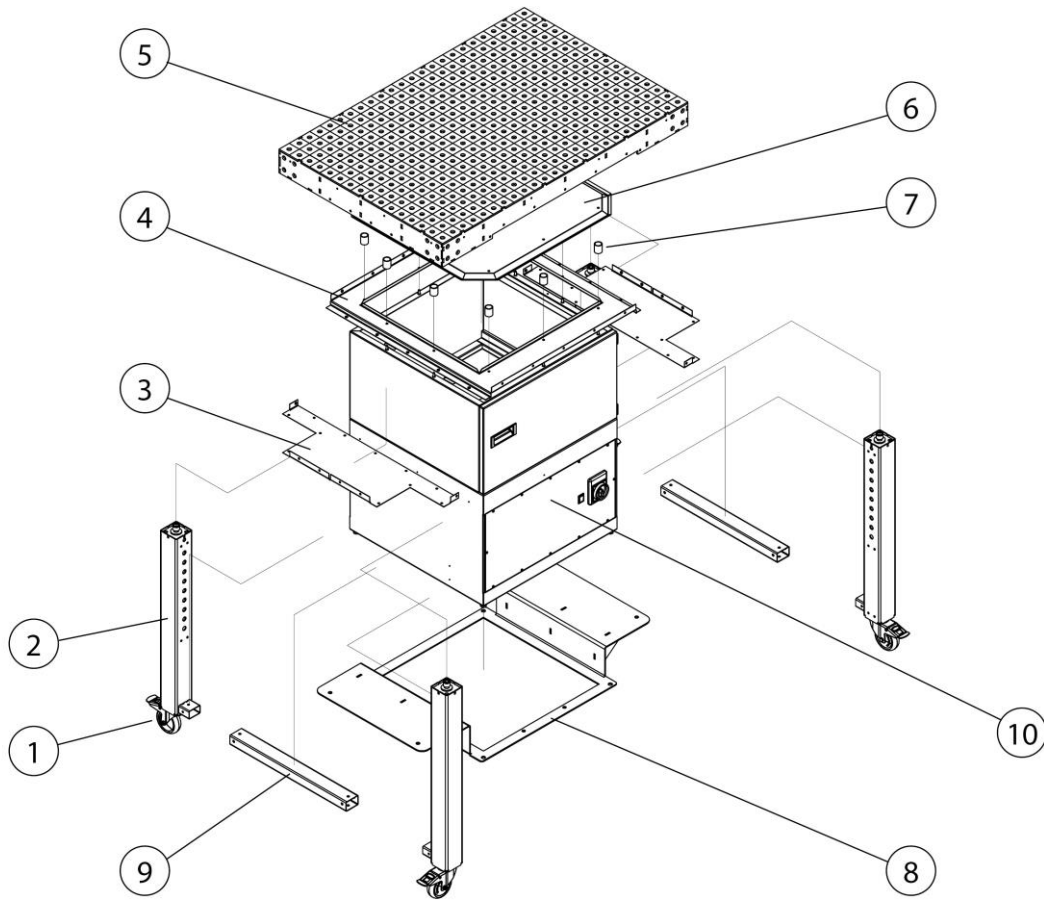

Fig. 2: Installation – Overview of components

Item	Description	Item	Description
1	Swivel castor with brake (4 x)	6	Spark plate
2	Table leg (4 x)	7	Spacer sleeve (10 x)
3	Dust pan (2 x)	8	Frame
4	Support frame	9	Strut (2 x)
5	Table top	10	Filter unit

Tab. 2: Installation – Overview of components

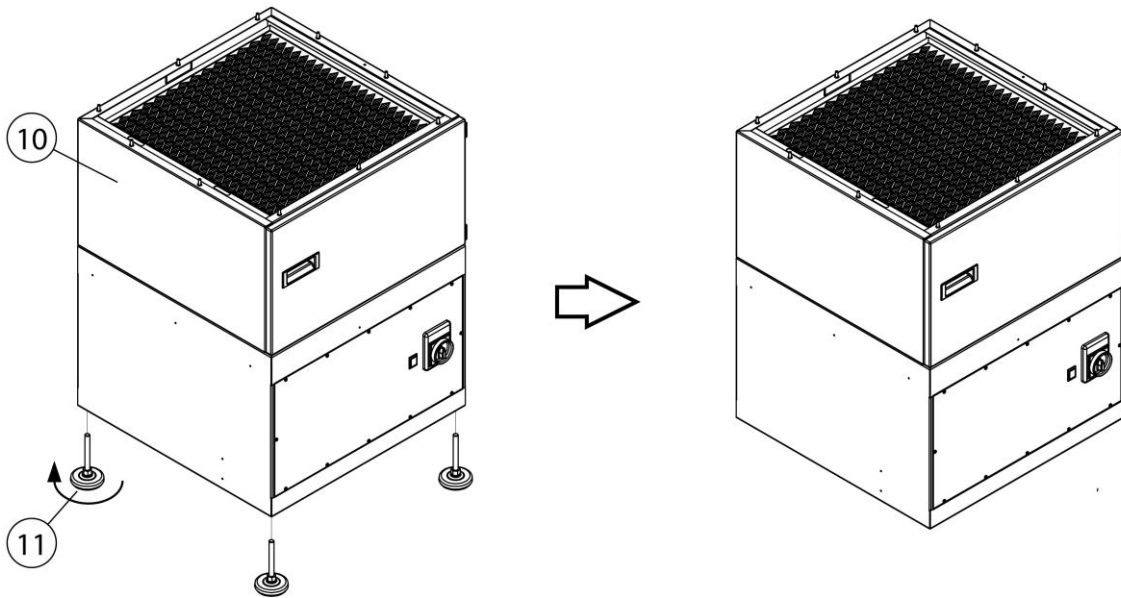

Fig. 3: Installation – Removing the machine feet

3. Remove the machine feet (item 11) from the filter unit (item 10). The machine feet are no longer required for further installation.

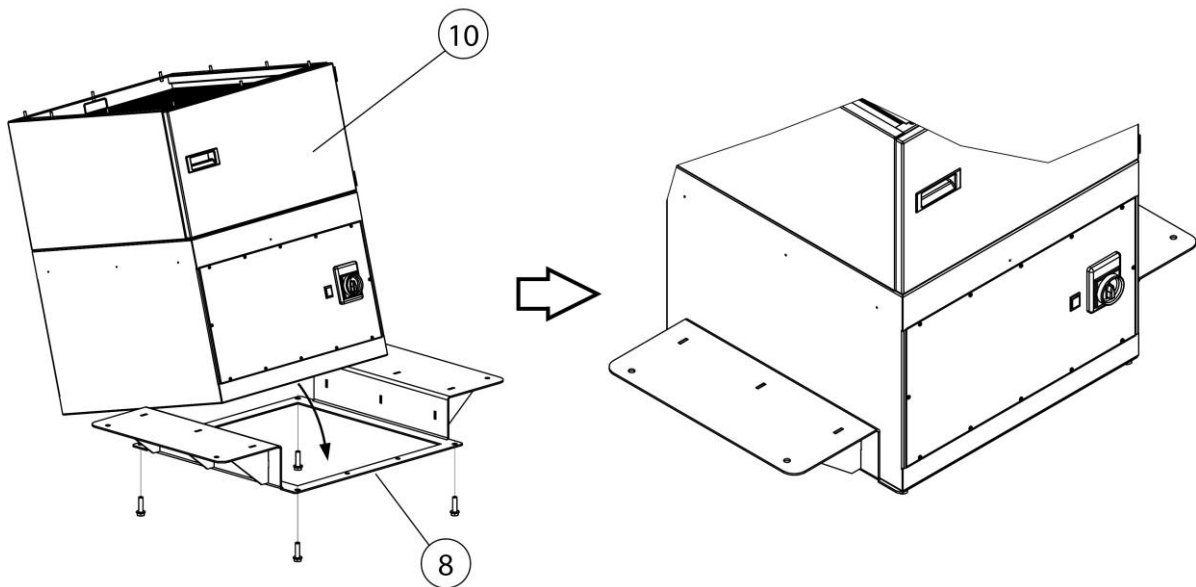

Fig. 4: Installation – Mount the filter unit on the support

4. Screw the filter unit (item 10) onto the support frame (item 8) as shown in the illustration by using the M12 hexagon head screws + washers.

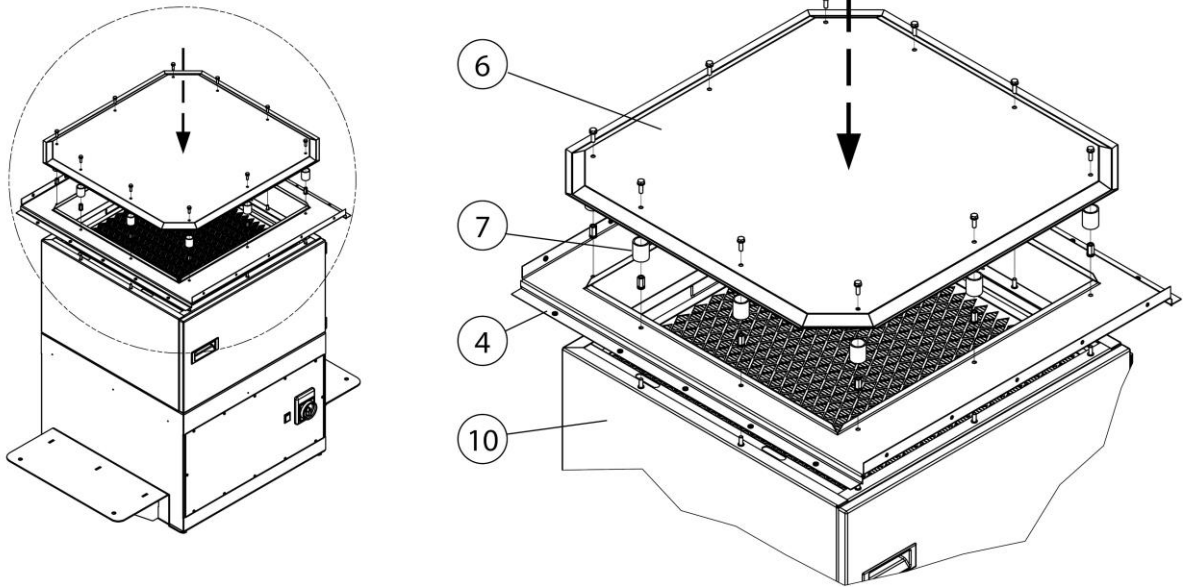

Fig. 5: Installation - Support frame + spark plate

5. Screw the support frame (item 4) and the spark plate (item 6) to the filter unit using the spacer sleeves (item 7) as shown in the illustration.

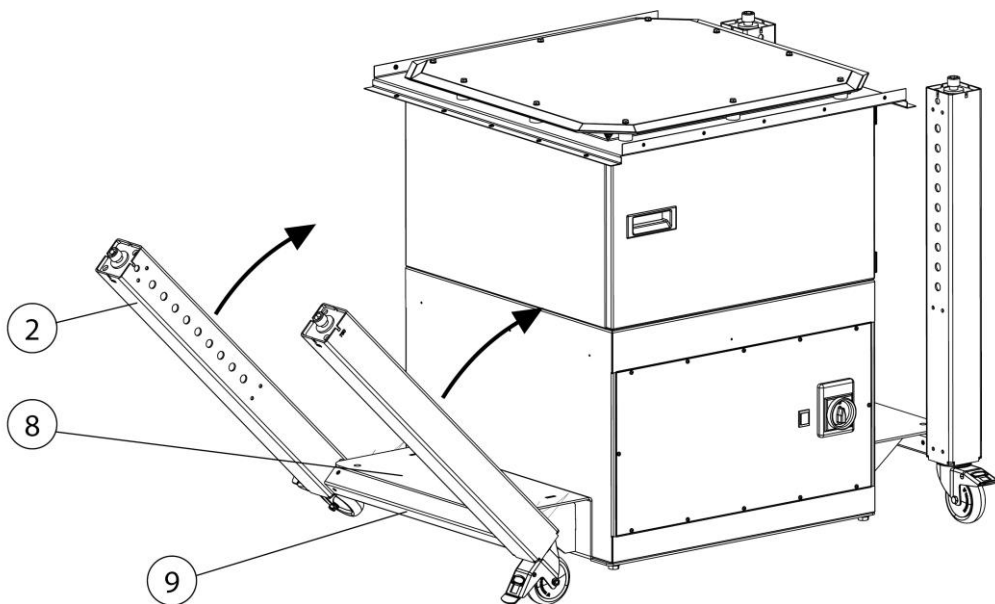

Fig. 6: Installation - Table legs

6. Connect the table legs (item 2) to the strut (item 9).
7. Then screw the table legs (item 2) to the support frame (item 9) as shown in the illustration.

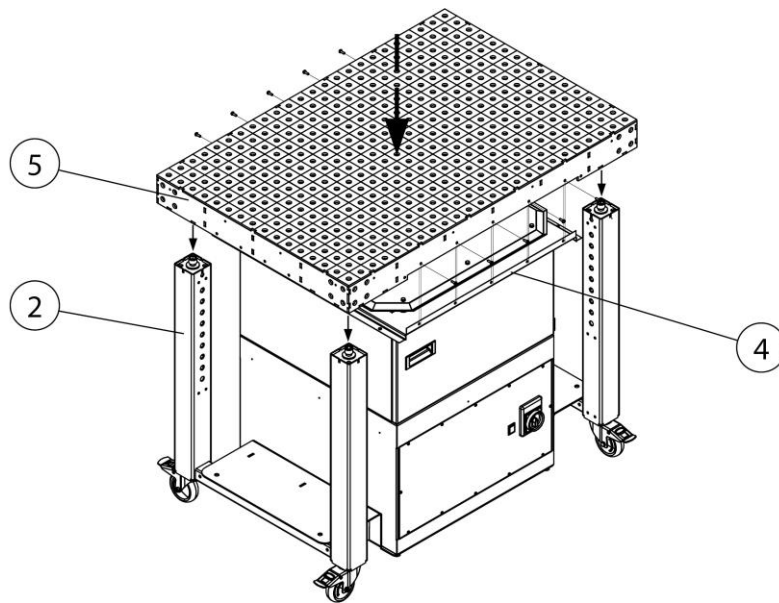

Fig. 7: Installation - Table top

8. Unscrew the hexagon socket screws of the table legs (item 2).
9. Then screw the table top (item 5) to the table legs (item 2) as shown in the illustration.
10. Screw the table top (item 5) to the side of the support frame (item 4).

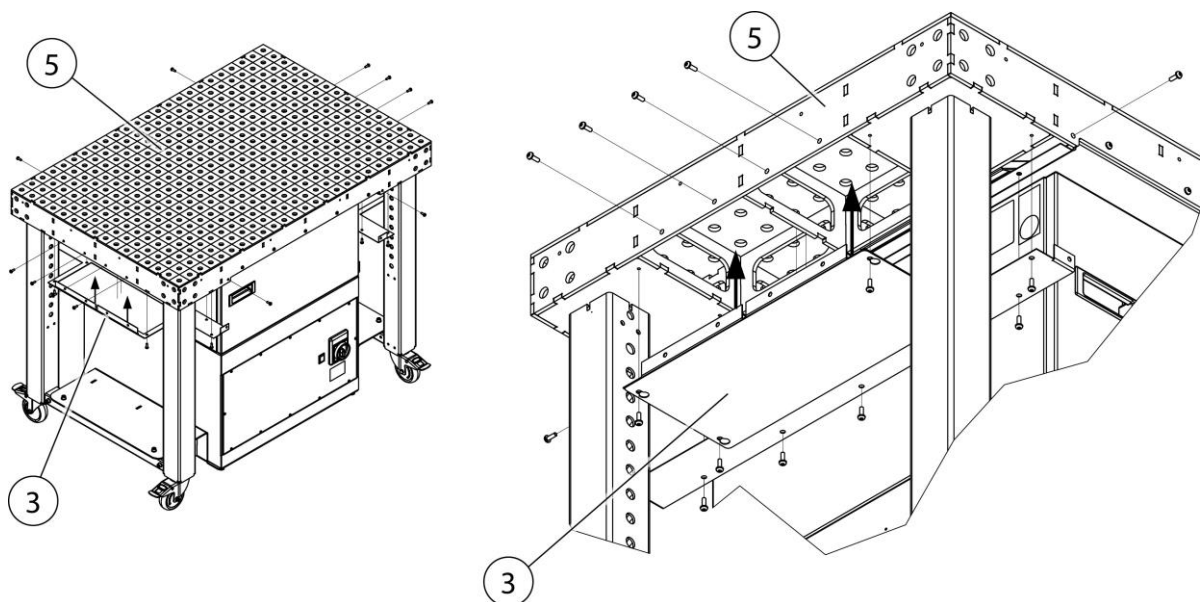

Fig. 8: Installation - Dust pan

11. Screw the dust pans (item 3) to the table top (item 5) and the support frame (item 4) as shown in the illustration.

Mounting the side walls - optional

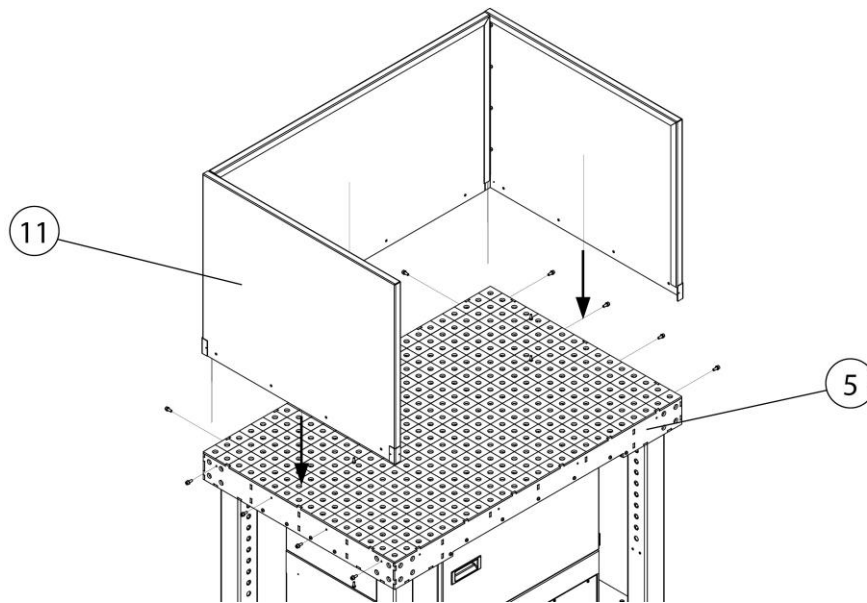

Fig. 9: Installation – side wall (optional)

Item	Description	Item	Description
5	Table top	11	Side wall

Tab. 3: Installation – side wall (optional)

1. Screw the side wall (item 11) to the table top (item 5) as shown in the illustration.

Checking the direction of fan rotation

The phase sequence/direction of rotation of the fan must be checked before commissioning. To do so, please proceed as follows:

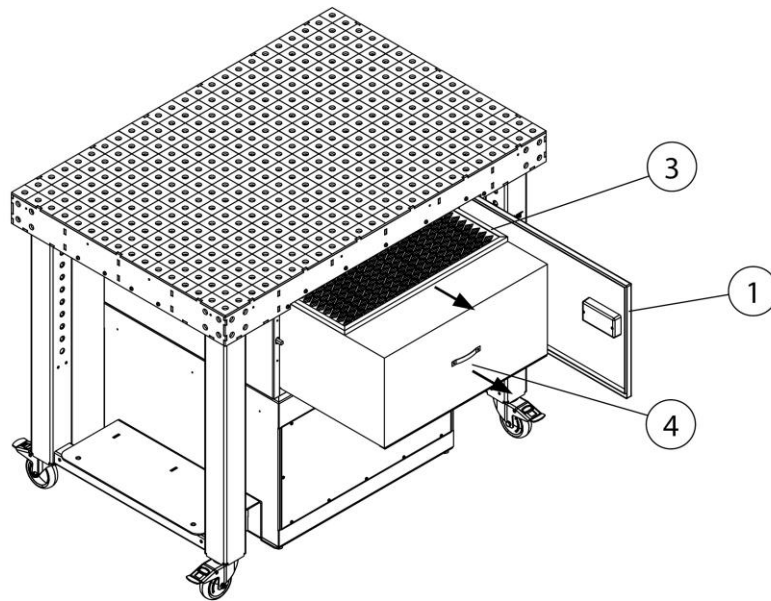

Fig. 10: Checking the direction of fan rotation

Item	Description	Item	Description
1	Maintenance door	3	Pre-filter
		4	Main filter

Tab. 4: Checking the direction of fan rotation

1. Open the maintenance door (item 1) and remove the filter elements (items 3+4) from the product.

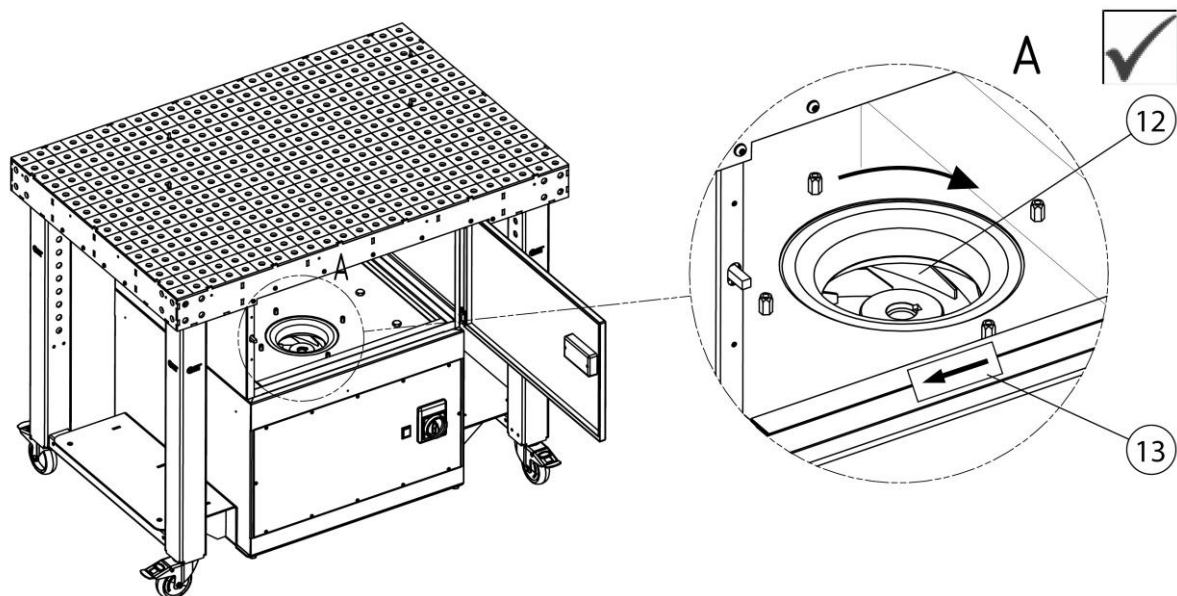

Fig. 11: Checking the direction of rotation of the fan impeller

Item	Description	Item	Description
12	Fan impeller	13	Indication arrow

Tab. 5: Checking the direction of rotation of the fan impeller

2. Connect the product to the mains.
3. Briefly switch on the product and immediately switch it off again. Observe the direction of rotation of the fan impeller (item 12). The correct direction of rotation is indicated by an arrow (item 13) on the product. If the direction of rotation is incorrect, two phases must be swapped in the CEE connection plug by a qualified electrician.

6 Use

Every person who deals with use, maintenance and repair of the product must have thoroughly read these operating instructions as well as the instructions for any attachment and accessory products and have understood them.

6.1 Qualification of the operating personnel

The operating company of the product may only commission persons to use the product independently if they are well-versed in this task.

Those familiar with this task includes those who have been instructed appropriately in the task and know the operating instructions as well as the operational issues in question.

The product should only be used by trained or instructed personnel. This is the only way to ensure safety and hazard awareness of all personnel during work.

6.2 Operating elements

The operating controls are located on the front of the product.

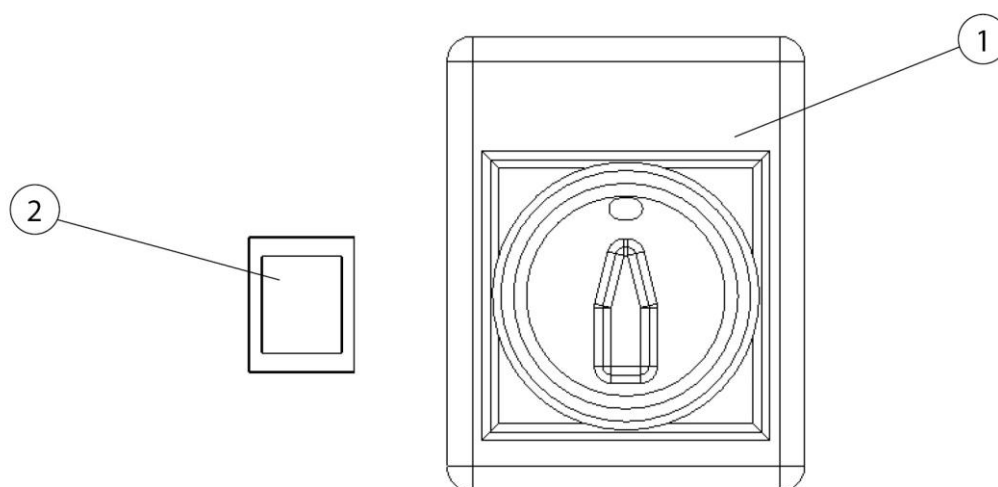

Fig. 12: Operating elements

Item	Description	Note
1	On/Off switch	Switches the product on or off
2	Signal light	Signals the required filter change

Tab. 6: Operating elements

6.3 Commissioning

⚠ WARNING

Danger due to faulty product condition.

The product must be fully installed before commissioning begins. All doors must be closed and the necessary connections must have been made.

1. Ensure that the product is supplied with power.
2. Start the product by turning the main switch.
3. The fan starts and the product is in operation.

In the event of a malfunction, the signal lamp lights up (see chapter "Troubleshooting").

7 Maintenance

The instructions in this chapter are intended as minimum requirements. Depending on the operating conditions, further instructions may be required to keep the product in optimal condition.

The maintenance and repair work described in this chapter must only be performed by specially trained repair personnel of the operating company.

Spare parts used must comply with the manufacturer's specified technical requirements.

This is guaranteed if original spare parts are used.

The safe and environmentally friendly disposal of operating materials and replacement parts must be ensured.

The safety instructions in these operating instructions must be observed during maintenance work.

7.1 Care

The care of the product is essentially limited to cleaning all surfaces of the product and – if present – checking the filter inserts.

The warning notices listed in the chapter "Safety notes for maintenance and fault removal" must be observed.

NOTE

The product may not be cleaned with compressed air. This may result in dust and/or dirt particles getting into the ambient air.

Proper care helps to maintain the product in a continuous functional state.

For optimum care and cleaning of the powder-coated surfaces, the following must be observed:

- Thoroughly clean the product monthly or as needed.
- Clean the exterior areas of the product with a suitable industrial vacuum cleaner of dust classification H or with damp soft cloths/industrial cotton wool.
- For stubborn dirt, use commercially available household cleaners. Avoid vigorous rubbing.
- Do not use any abrasive agents that scratch.
- Do not use any acidic or strongly alkaline cleaning agents.
- Do not use organic solvents containing esters, ketones, alcohols, hydrocarbons or similar.

7.2 Maintenance

Regular inspection and servicing have a positive effect on the reliable functioning of the product and should be carried out at least once a year.

Except for the necessary filter replacements, the product operates maintenance-free.

Observe the warning notices for servicing and troubleshooting in the "Safety" chapter.

7.2.1 Changing the filter – Safety instructions

The life of the filter inserts depends on the type and amount of deposited particles.

As the dust accumulation in the filter increases, its flow resistance increases and the extraction capacity of the product decreases.

Even with products that may have automatic filter cleaning, adhering deposits can reduce the extraction capacity.

A filter change is required.

▲ WARNING

Health hazards caused by welding fume particles

Do not inhale welding dust / smoke! Serious injury to the lungs and respiratory tract is possible!

Sweat smoke contains substances that can cause cancer!

Skin contact with welding fume particles can cause skin irritation in sensitive individuals.

To avoid contact with and inhalation of these dust particles, wear disposable overalls, protective goggles, gloves and a suitable Class FFP2 respiratory protection filter mask in accordance with EN 149.



⚠ WARNING

Cleaning the filter inserts is not permitted. This inevitably leads to damage to the filter element, meaning the filter ceases to function and hazardous substances enter the air.

During the work described in the following section, pay particular attention to the seal on the main filter. Only an undamaged seal allows the product to achieve a high filter efficiency. Main filters with a damaged seal must therefore be replaced every time.

NOTE

Products with W3 certification according to requirements for W3/IFA certified welding fume separation class. (See "Technical data" chapter)

The W3 approval becomes void if:

- The product is used other than as intended or is subject to constructive modifications.
 - Non-original spare parts, in accordance with the spare parts list, are used.
-
- Only original replacement filters, because they guarantee the necessary filter efficiency and are matched to the product and its performance characteristics.
 - Switch the product off using the on/off switch.
 - Secure the product against unintentional switching on. If available, pull out the mains plug or secure the main switch in the 0 position with a padlock.
 - Disconnect the pressure supply, if present, and let the compressed air present in the product flow out via the condensate drain valve.

7.2.2 Changing filters

NOTE

The product has a pre-filter and a main filter. Some products also have an activated charcoal filter or this can be retrofitted if required. (see chapter "Spare parts + Accessories")

The service life of the activated charcoal filter depends on the respective conditions of use and cannot therefore be predicted. However, the activated charcoal filter should be replaced at the latest when the main filter is changed.

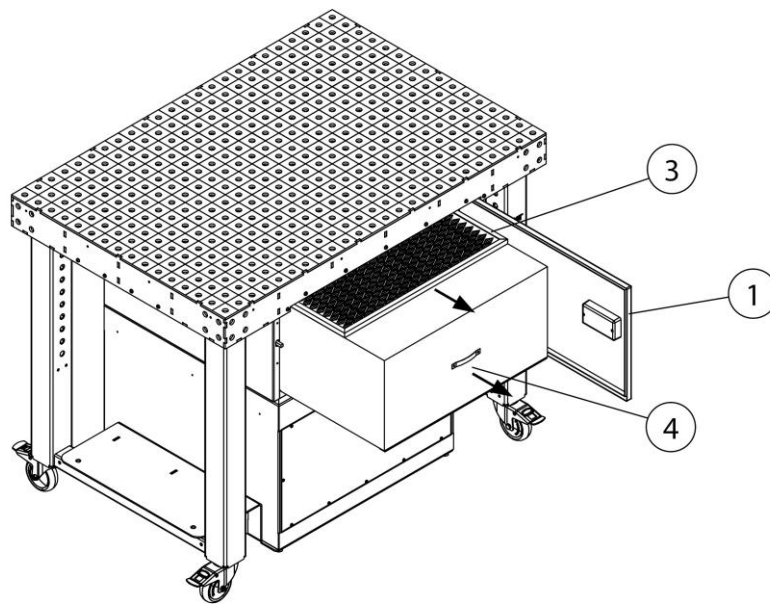

Fig. 13: Filter change – pre-filter + main filter

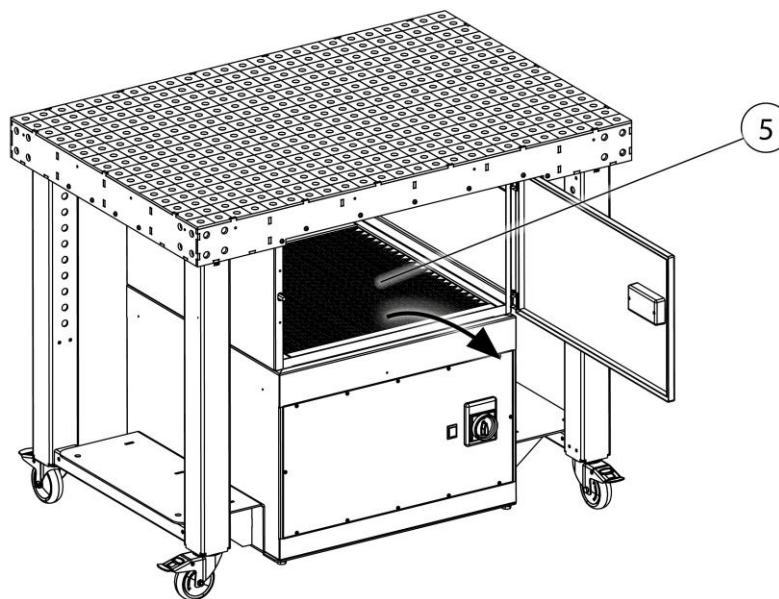

Fig. 14: Filter change – activated charcoal filter (optional)

Item	Description	Item	Description
1	Maintenance door	3	Pre-filter
		4	Main filter
		5	Activated charcoal filter (optional)

Tab. 7: Filter change – pre-filter + main filter

Perform the filter change as follows:

1. Switch off the product at the main switch and secure it against unintentional restart by pulling out the mains plug.
2. Provide a new main filter (item 4) and, if necessary, a new pre-filter (item 3) + activated charcoal filter (item 5).
3. Open the maintenance door (item 1) and carefully remove the filter elements (items 1+2) and, if present, the activated charcoal filter (item 4) out of the product without stirring up dust.

NOTE

The pre-filter (item 3) can be used several times. In the event of mechanical destruction of the surface, it must be changed.

4. Carefully place the saturated filter elements in a disposal bag, seal it airtight and dispose of it according to the instructions.

5. Re-insert the new main filter (item 4), the pre-filter (item 3) and the activated charcoal filter (item 5), if required, into the product in reverse order, making sure that they are installed in the correct position.
6. Close the maintenance door (item 1) and put the product back into operation. (see also chapter "Commissioning")

NOTE

Observe the information printed on the filter element when changing the filter.

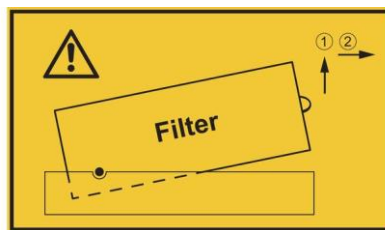

Fig. 15: Information for filter change

7.3 Maintenance - Cleaning the perforated plate support

The inside of the perforated plate support must be cleaned at regular intervals.

The length of time before cleaning is required depends on the type and quantity of the insert and the deposited dust particles.

Clean as follows.



Abb. 16: Reinigung der Lochblechauflage

Pos.	Designation	Pos.	Designation
1	Perforated plate support	3	Maintenance cover (2 x)
2	Hexagon socket screw		

Tab. 8: Cleaning the perforated plate support

1. Remove the maintenance cover (Pos. 3) as shown in the illustration. To do this, loosen the four hexagon socket screws (item 2) and carefully remove the maintenance cover (Pos. 3) without stirring up dust.
2. Carefully clean the inside of the perforated plate support (item 1) with a hand brush without stirring up dust.
3. place the dust in a disposal bag and dispose of it according to the instructions.
4. close the two maintenance covers (pos. 3) again and put the product back into operation. See chapter Commissioning.

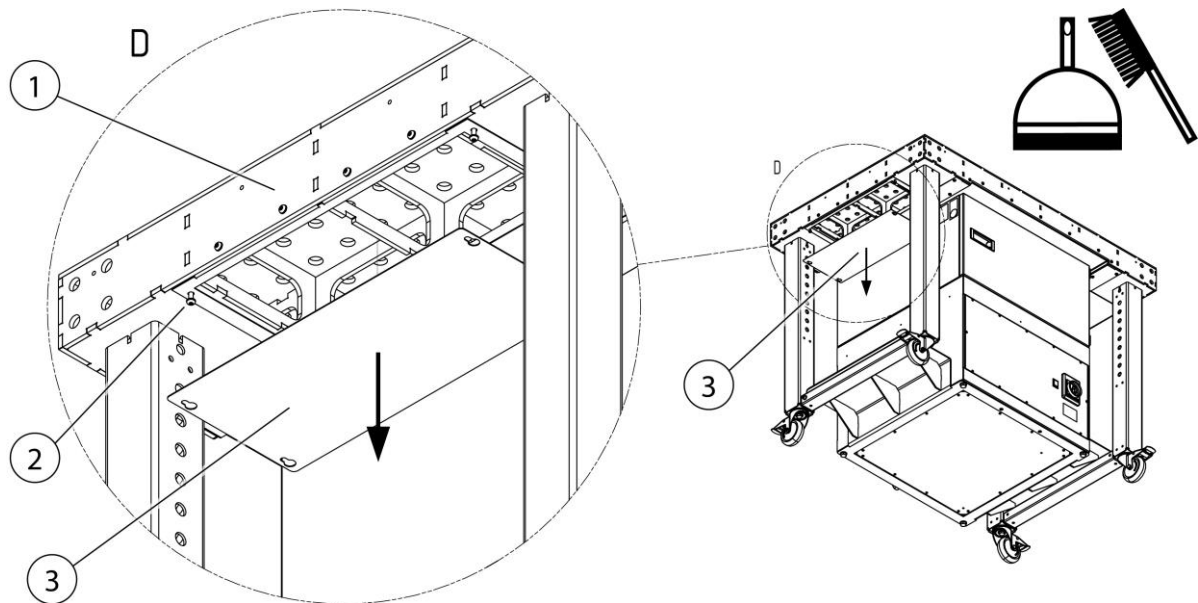
7.4 Troubleshooting

Fault	Possible cause	Note
Product does not start	No power supply available	Have the power supply checked by a qualified electrician
Extraction capacity too low/non-existent	Filter inserts saturated	Check/change filter inserts
	Rotation direction of the fan is incorrect	Have a qualified electrician swap two phases in the CEE connection plug. See also chapter: Assembly
	Clean air outlet covered	Keep clean air outlet clear
Red signal light lights up	The set minimum extraction rate has not been reached. Filter inserts saturated	Carry out filter change
Dust particles escape on the clean air side	Filter insert damaged	Check/change filter inserts
Product switches off	Motor protection switch has triggered	Have the fan motor checked by a qualified electrician
	Motor temperature too high	Allow motor to cool down/check cooling air openings

Tab. 9: Troubleshooting

NOTE

If the fault cannot be corrected by the customer, please contact the manufacturer's service department.

7.5 Emergency measures

In case of fire of the product or its detection elements, the following steps should be taken if necessary:

1. Disconnect the product from the mains! If present; pull out mains plug; set main switch to 0-position; disconnect supply fuses.
2. If present, disconnect the compressed air supply.
3. Fight fire with a commercially available dry powder extinguisher.

4. Notify local fire brigade if necessary.

⚠ WARNING

Do not open products with maintenance door. Flash flame formation!
In the event of a fire, do not touch the product under any circumstances
without proper protective gloves. Risk of burns!

8 Disposal

▲ WARNING

Skin contact with welding fumes, etc. can cause skin irritation in susceptible individuals.

Disassembly work on the product may only be carried out by trained and authorised personnel while complying with the safety rules and the applicable accident prevention regulations.

Serious injury to the lungs and respiratory tract is possible!

In order to avoid contact with and inhalation of dust particles, use protective clothing, gloves and a blower respirator system.

The release of hazardous dust particles must be avoided during dismantling work so that persons in the vicinity are not harmed.

▲ CAUTION

All work on and with the product must comply with the legal obligations for waste avoidance and proper recycling/disposal.

8.1 Plastics

Plastics, if present, must be sorted as far as possible. Plastics must be disposed of in compliance with the legal requirements.

8.2 Metals

Metals, if present, must be separated and disposed of. Disposal must be carried out by an authorised company.

8.3 Filter elements

Filter elements, if present, must be disposed of in compliance with the legal requirements.

9 Annex

9.1 EC compliance statement

Designation: Welding fume filter unit
Series: FilterTable
Type: **950400020, 950400021, 95040000103, 95040000105** (if necessary, different item numbers for other product variants)
Machine ID: See name plate in front section of this operating manual
This product is developed, designed and manufactured in accordance with EC directives
2006/42/EC – Machinery Directive

The product continues to comply with the provisions of the
2014/30/EU – EMC Directive
2014/35/EU – Low Voltage Directive
2011/65EU – RoHS Directive

Company: At the sole responsibility of
KEMPER GmbH
Von-Siemens-Str. 20, D-48691 Vreden

The following harmonised standards are used:

EN ISO 12100:2010 Safety of machinery - General principles for design
EN ISO 13857:2019 Safety of machinery - Safety distances
EN ISO 13854:2019 Safety of machinery - Minimum gaps
EN ISO 21904-1:2020 Health and safety in welding and allied processes
EN IEC 61000-6-2:2019 Electromagnetic compatibility (EMC) - Part 6-2: Generic standards - Immunity standard for industrial environments
EN IEC 61000-6-4:2019 Electromagnetic compatibility (EMC) - Part 6-4: Generic standards - Emission standard for industrial environments
EN 60204-1:2018 Safety of machinery - Electrical equipment of machines
EN ISO 13849-1:2015 Safety of machinery - Safety-related parts of control systems

A complete list of standards, directives and specifications applied is available from the manufacturer. The operating manual belonging to the product is available.

Additional information:

If it is not used for as intended or the design is altered, the Declaration of Conformity expires, unless confirmed in writing by us as manufacturers.

Mr Marcel Kusche is authorised to compile the technical documentation. Kemper GmbH, Von-Siemens-Str. 20, 48691 Vreden, Germany

Vreden, 28.04.2025

Place, date

B. KEMPER



CEO

Identification of the signatory

9.2 UKCA Declaration of Conformity

Designation: Welding fume filter unit
 Series: FilterTable
 Type: **950400020, 950400021, 95040000103, 95040000105** (possibly different article numbers for other product variants)
 Machine ID: See name plate in front section of this operating manual
 This product is developed, designed and manufactured in accordance with the UKCA directives
 Supply of Machinery (safety) Regulations 2008

The product continues to comply with the provisions of the Electromagnetic Compatibility Regulations 2016
 Electrical Equipment (Safety) Regulations 2016

At the sole responsibility of
 Company: **KEMPER GmbH**
 Von-Siemens-Str. 20, D-48691 Vreden

The following designated standards and technical specifications have been applied:

- BS EN ISO 12100:2010 Safety of machinery - General principles for design
- BS EN ISO 13857:2019 Safety of machinery - Safety distances
- BS EN ISO 13854:2019 Safety of machinery
- BS EN ISO 21904-1:2020 Health and safety in welding and allied processes
- BS EN ISO 4414:2010 fluid power - General rules and safety requirements for systems and their components
- BS EN IEC 61000-6-2:2019 Electromagnetic compatibility (EMC) - Part 6-2: Generic standards - Immunity standard for industrial environments
- BS EN IEC 61000-6-4:2019 Electromagnetic compatibility (EMC) - Part 6-4: Generic standards - Emission standard for industrial environments
- BS EN 60204-1:2018 Safety of machinery - Electrical equipment of machines
- BS EN ISO 13849-1:2016 Safety of machinery - Safety-related parts of control systems
- BS EN IEC 63000:2018 Technical documentation for the assessment of electrical and electronic products with respect to the restriction of hazardous substances

A complete list of standards, directives and specifications applied is available from the manufacturer. The operating manual belonging to the product is available.

Additional information:

If it is not used for as intended or the design is altered, the Declaration of Conformity expires, unless confirmed in writing by us as manufacturers.

UK Authorised Representative (for authorities only): Mr. Marc Crawford
 United Kingdom KEMPER (U.K.) Ltd.
 Venture Court, 2 Debdale Road, Wellingborough, Northamptonshire NN8 5AA

Vreden, 28.04.2025

Place, date



B. Kemper

CEO

Identification of the signatory

9.3 Technical data

Designation	950400020	950400021
Filter		
Filter stages	2	
Filter method	Disposable filter	
Cleaning method	--	
Filter surface m ² [ft ²]	15.8 [170]	
Number of filter elements	1	
Total filter surface m ² [ft ²]	15.8 [170]	
Type of filter	Compact filter with aluminium separators	
Filter material	Non-woven fibre	
Filter efficiency ≥ %	99.9	
Welding fumes class	--	
IFA test standard	--	
Filter class/Dust classification	M	
Basic data		
Maximum fan capacity m ³ /h [CFM]	3000 [1766]	
Extraction capacity m ³ /h [CFM]	1400 [824]	
Vacuum Pa [inch WC]	3000 [12]	
Motor power kW [hp]	1.5 [2.01]	
Power supply/rated current/protection type/ISO class	See name plate	
Permissible ambient temperature °C [F]	-10 to +40 [+14 to +104]	
Duty cycle %	100	
Noise level dB(A)	71	
Compressed air supply bar [PSI]	--	
Compressed air consumption NI/min [CFM]/ Compressed air class	--	
Dimensions of the basic product (W x H x D)	See dimension sheet	
Basic product weight kg [lbs]	245 [541]	
Max. capacity of work table [kg] [lbs]	1000 [2205]	

Additional information	
Fan type	Radial fan

Tab. 10: Technical data

9.4 Dimensions sheet

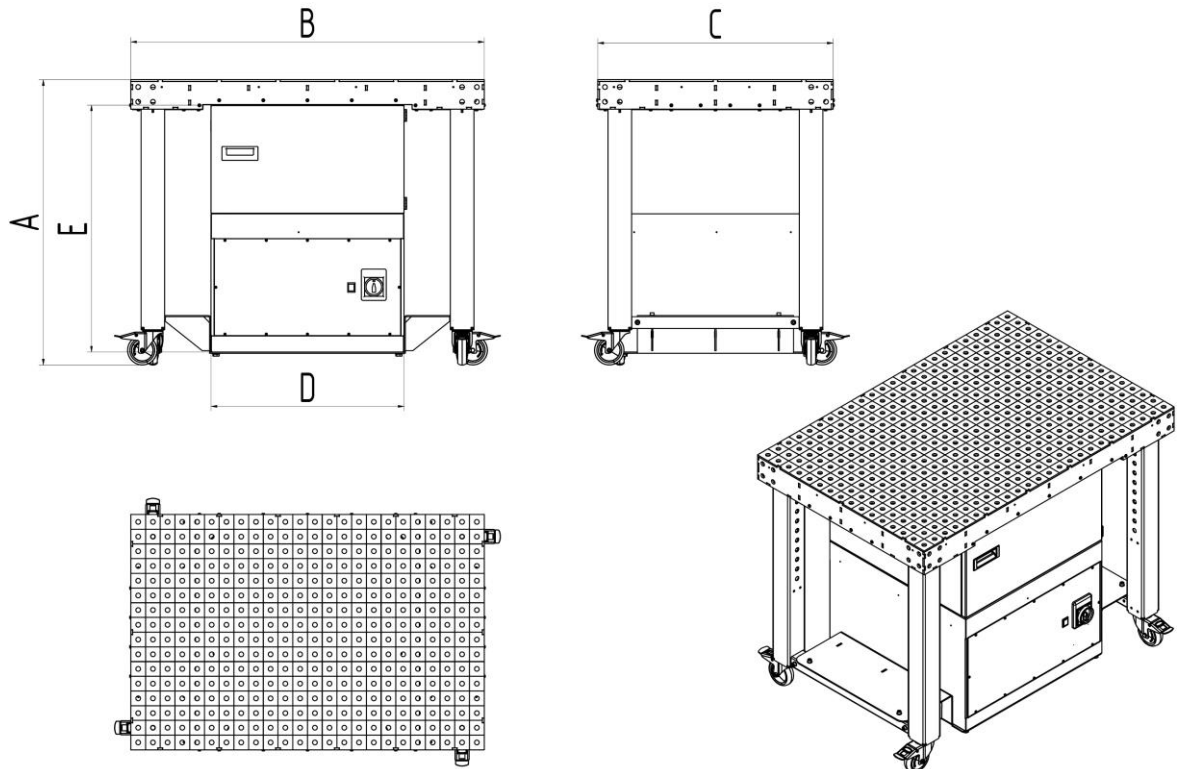

Fig. 17: Dimensions sheet

Symbol	Dimensions mm [in]	Symbol	Dimensions mm [in]
A	970 [38.2]	D	655 [25.8]
B	1200 [47.2]	E	845 [33.3]
C	800 [31.5]		

Tab. 11: Dimensions table

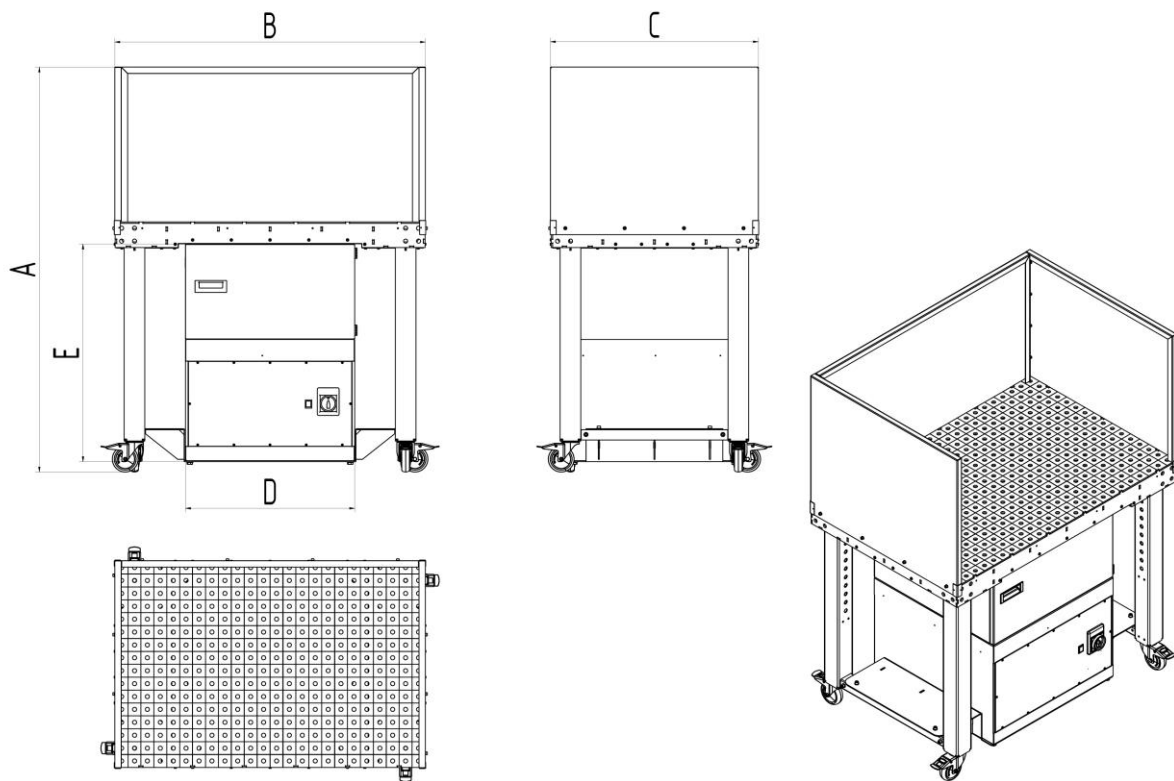

Fig. 18: Dimension sheet with side wall

Symbol	Dimensions mm [in]	Symbol	Dimensions mm [in]
A	1570 [61.8]	D	655 [25.8]
B	1203 [47.4]	E	845 [33.3]
C	803 [31.6]		

Tab. 12: Dimension table with side wall

9.5 Spare parts and accessories

Consec. no.	Description	Item no.
1	Main filter	1090010
2	Pre-filter, aluminium mesh	1090013
3	Activated carbon filter	1090345
4	Protective wall set	998803719

Tab. 13: Spare parts and accessories

9.6 Table accessory GWT

Suitable table accessory **System 16 - 6 mm** on www.german-weldingtools.com

Deutschland (HQ)**KEMPER GmbH**

Von-Siemens-Str. 20
D-48691 Vreden
Tel. +49 2564 68-0
Fax +49 2564 68-120
mail@kemper.eu
www.kemper.eu

United Kingdom**KEMPER (U.K.) Ltd.**

Venture Court
2 Debdale Road
Wellingborough
Northamptonshire NN8 5AA
Tel. +44 1327 872 909
Fax +44 1327 872 181
mail@kemper.co.uk
www.kemper.co.uk

France**KEMPER sàrl**

7 Avenue de l'Europe
F-67300 Schiltigheim
Si vous appelez de France
Tél. +33 800 91 18 32
Fax +33 800 91 90 89
De Belgique ou de l'étranger
Tél. +492564 68-135
Fax +492564 68-40135
mail@kemper.fr
www.kemper.fr

China**KEMPER China**

Floor 2, Building 6
No. 500 Huapu Road
Shanghai 201799
P.R. of China
Tel. +86 (21) 5924-0978
Fax +86 1852-1069-401
info@kemper-china.com.cn
www.kemper.cn.com

Česká Republika**KEMPER spol. s r.o.**

Pyšelská 393
CZ-257 21 Poříčí nad Sázavou
Tel. +420 317 798-000
Fax +420 317 798-888
mail@kemper.cz
www.kemper.cz

United States**KEMPER America, Inc.**

2460 Industrial Park BLVD.
Cumming, GA 30041
Tel. +1 770 416 7070
Fax +1 770 828 0643
info@kemperamerica.com
www.kemperamerica.com

Nederland**KEMPER B.V.**

Demmersweg 92
Begane grond
7556 BN Hengelo
Tel. +492564 68-137
Fax +492564 68-120
mail@kemper.eu
www.kemper.eu

España**KEMPER IBÉRICA, S.L.**

Avda Diagonal, 421 3º
E-08008 Barcelona
Tel. +34 902 109-454
Fax +34 902 109-456
mail@kemper.es
www.kemper.es

India**KEMPER India**

55, Ground Floor, MP Mall
MP Block, Pitam Pura
New Delhi -110034
Tel. +91.11.42651472
mail@kemper-india.com
www.kemper-india.com

Polska**Kemper Sp. z o.o.**

ul. Grzybowska 87
00-844 Warszawa
Tel. +48 22 5310 681
Faks +48 22 5310 682
info@kemper.pl
www.kemper.pl

